



ICE MAKER

Use & Care Guide

Table of Contents 2

TABLE OF CONTENTS

ICE MAKER SAFETY	3
PARTS AND FEATURES	4
ICE MAKER INSTALLATION	5
Unpacking	5
Location Requirements	5
Electrical Requirements	5
Leveling	6
Water Supply Connection	6
Reversing the Door Swing	8
Normal Sounds	9
ICE MAKER USE	10
How Your Ice Maker Works	10
Using the Controls	10
ICE MAKER CARE	10
Cleaning Exterior Surfaces.....	10
Cleaning the Ice Maker System.....	11
Cleaning the Condenser	11
Cleaning the Interior Components.....	12
Vacation and Moving Care.....	12
TROUBLESHOOTING	13
WARRANTY	14

ICE MAKER SAFETY

Your safety and the safety of others are very important.

We have provided many important safety messages in this manual and on your appliance. Always read and obey all safety messages.



This is the safety alert symbol.

This symbol alerts you to potential hazards that can kill or hurt you and others.

All safety messages will follow the safety alert symbol and either the word "DANGER" or "WARNING." These words mean:

! DANGER

You can be killed or seriously injured if you don't immediately follow instructions.

! WARNING

You can be killed or seriously injured if you don't follow instructions.

All safety messages will tell you what the potential hazard is, tell you how to reduce the chance of injury, and tell you what can happen if the instructions are not followed.

IMPORTANT SAFETY INSTRUCTIONS

WARNING: To reduce the risk of fire, electric shock, or injury when using your ice maker, follow these basic precautions:

- Plug into a grounded 3 prong outlet.
- Do not remove ground prong.
- Do not use an adapter.
- Do not use an extension cord.
- Disconnect power before cleaning.
- Disconnect power before servicing.
- Replace all panels before operating.
- Use two or more people to move and install ice maker.

SAVE THESE INSTRUCTIONS

PARTS AND FEATURES

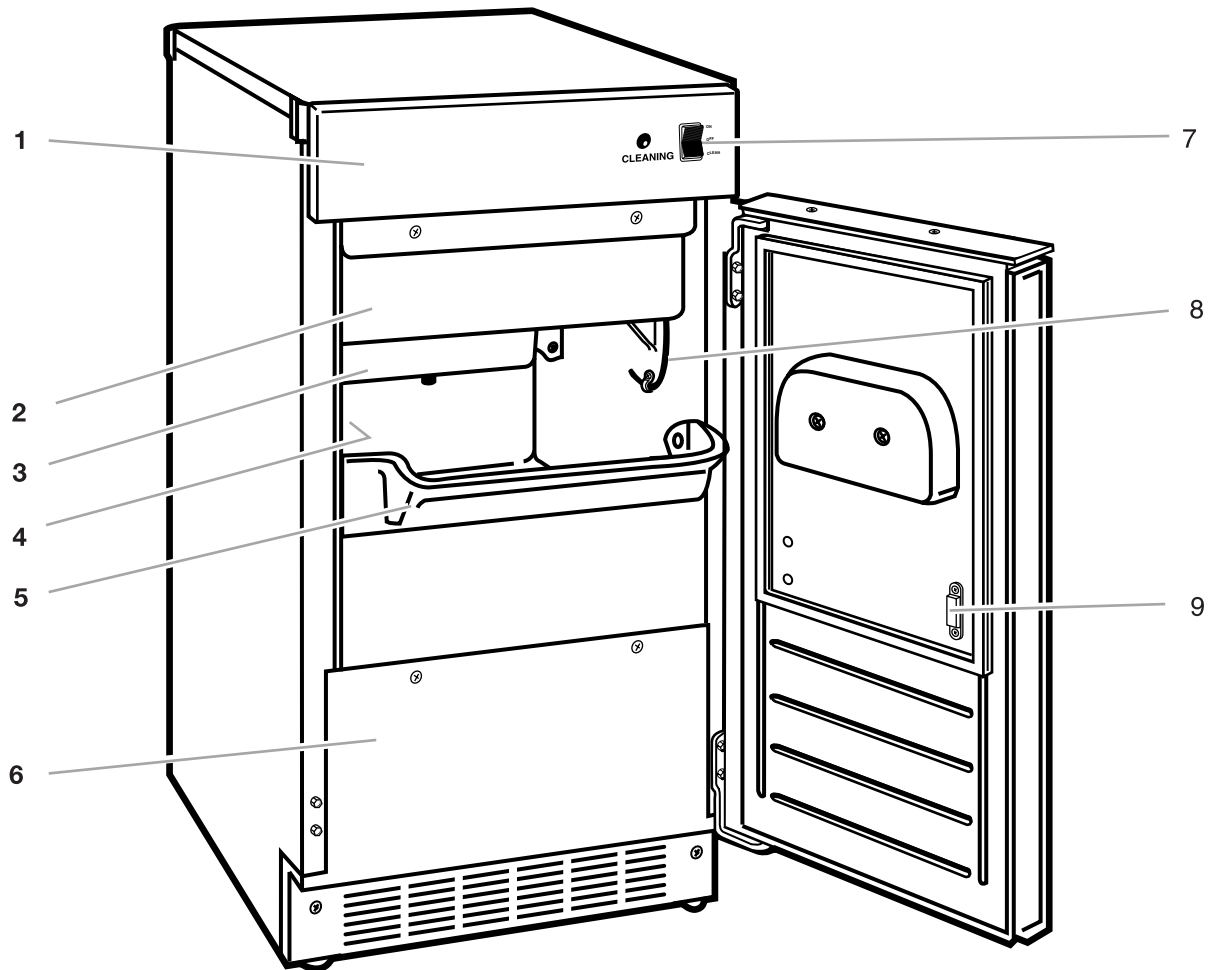

- 1. Upper Access Panel
- 2. Cutter Grid Cover
- 3. Water Pan
- 4. Model Serial Number Label (on left cabinet wall)
- 5. Ice Retainer Baffle
- 6. Lower Access Panel
- 7. Control Panel
- 8. Ice Level Sensor
- 9. Magnetic Door Catch

ICE MAKER INSTALLATION

Unpacking

⚠ WARNING

Excessive Weight Hazard

Use two or more people to move and install ice maker.

Failure to do so can result in back or other injury.

Removing packaging materials

Remove tape and glue from your ice maker before using.

- To remove any remaining tape or glue, rub the area briskly with your thumb. Tape or glue residue can also be easily removed by rubbing a small amount of liquid dish soap over the adhesive with your fingers. Wipe with warm water and dry.
- Do not use sharp instruments, rubbing alcohol, flammable fluids, or abrasive cleaners to remove tape or glue. These products can damage the surface of your ice maker.

Cleaning before use

After you remove all of the packaging materials, clean the inside of your ice maker before using it. See the cleaning instructions in the "Ice Maker Care" section.

Location Requirements

- To ensure proper ventilation for your ice maker, the front side must be completely unobstructed. The unit may be closed-in on the top and three sides, but the installation should allow the ice maker to be pulled forward for servicing if necessary.
- Installation of the ice maker requires a cold water supply inlet of ¼ in. (6.35 mm) OD soft copper tubing with a shutoff valve and either a gravity-drain system or condensate pump to carry the water to an existing drain.
- Choose a well ventilated area with temperatures above 55°F (13°C) and below 100°F (38°C). Best results are obtained between 70°F (21°C) and 90°F (32°C). This unit **MUST** be installed in an area protected from the elements, such as wind, rain, water spray, or drip.
- When installing the ice maker under a counter, follow the recommended opening dimensions shown. Place electrical and plumbing fixtures in the recommended location as shown.

NOTE: Do not kink or pinch the power supply cord between the ice maker and cabinet.

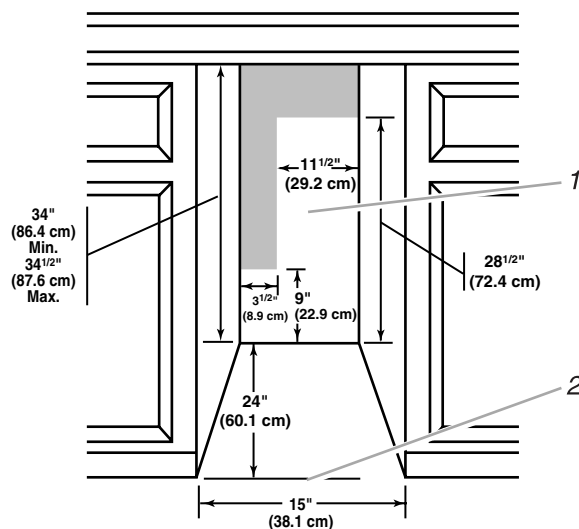

1. Recommended Location for Electrical and Plumbing Fixtures
2. Floor Level

- You should choose a location where the floor is even. It is important for the ice maker to be level in order to work properly. If needed, you can adjust the height of the ice maker by changing the position of the rear wheels. See the "Leveling" section.

Electrical Requirements

⚠ WARNING



Electrical Shock Hazard

Plug into a grounded 3 prong outlet.

Do not remove ground prong.

Do not use an adapter.

Do not use an extension cord.

Failure to follow these instructions can result in death, fire, or electrical shock.

Before you move your ice maker into its final location, it is important to make sure you have the proper electrical connection:

A 115 Volt, 60 Hz., AC only 15 ampere electrical supply, properly grounded in accordance with the National Electrical Code and local codes and ordinances, is required.

It is recommended that a separate circuit, serving only your ice maker, be provided. Use a receptacle which cannot be turned off by a switch or pull chain.

Recommended grounding method

For your personal safety, this appliance must be grounded. This appliance is equipped with a power supply cord having a 3 prong grounding plug. To minimize possible shock hazard, the cord must be plugged into a mating, 3 prong, grounding-type wall receptacle, grounded in accordance with the National Electrical Code and local codes and ordinances. If a mating wall receptacle is not available, it is the personal responsibility of the customer to have a properly grounded, 3 prong wall receptacle installed by a qualified electrician.

Leveling

It is important for the ice maker to be level in order to work properly. Depending upon where you install the ice maker, you may need to make several adjustments to level it.

Tools required

- Carpenter's level
- Adjustable wrench
- ¼ in. socket wrench

Undercounter installation

If you are installing the ice maker under a countertop, then you may need to adjust the height of the ice maker. The adjustable rear wheels are preset to position 1 for a cabinet opening height of 34 in. (86.4 cm).

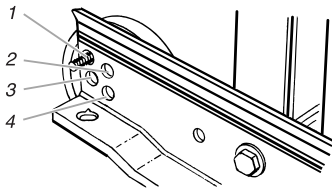

1. For cutout height of 34 in. (86.4 cm)
2. For cutout height of 34¹/₈ in. (86.7 cm)
3. For cutout height of 34⁵/₁₆ in. (87.2 cm)
4. For cutout height of 34¹/₂ in. (87.6 cm)

To adjust the rear wheel height

1. Using a ¼ in. socket wrench, remove the five screws from the rear access panel and carefully pull the panel away from the drain hose.
2. Using a ⅝ in. or adjustable wrench, remove the screw that holds the rear wheel.
NOTE: Push up against the top back of the ice maker to take some weight off of the wheels and make it easier to remove the screws.
3. Move the rear wheel and screw to a new position as needed for your cabinet opening height. Tighten the screw completely.
4. Repeat Steps 2 and 3 to change the position of the wheel on the other side.
5. Replace the rear panel and screws. Be sure that the drain tube is positioned in the opening provided.
6. Use the front leveling legs to make sure the product is level.

To adjust the front leveling legs

Your ice maker has two adjustable leveling legs to help you steady the product and make sure it is level.

NOTE: It is easier to adjust the leveling legs if you have another person to assist you.

1. Place a carpenter's level on top of the product to see if the ice maker is level from front to back and side to side.
2. Push up on the top front of the ice maker, and then locate the leveling screws that are on the bottom front of the product.
3. Using an adjustable wrench, change the height of the legs as follows:
 - Turn the leveling leg to the right to lower that side of the ice maker.
 - Turn the leveling leg to the left to raise that side of the ice maker.

NOTE: The ice maker should not wobble. Use shims to add stability when needed.

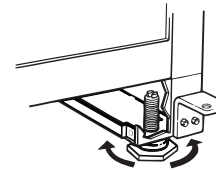

4. Use a carpenter's level to recheck the ice maker to see that it is even from front to back and side to side. If the ice maker is not level, repeat Steps 2 and 3. If the ice maker is level, go to the "Water Supply Connection" section.

Freestanding installation

If you are not installing your ice maker under a countertop, you will probably not need to adjust the rear wheel height. Follow the steps outlined in "To adjust the front leveling legs" earlier in this section.

NOTE: The ice maker should not wobble. Use shims to add stability when needed.

Water Supply Connection

Read all directions carefully before you begin.

IMPORTANT:

- All installations must be in accordance with local plumbing codes requirements.
- Use copper tubing and check for leaks.
- Install copper tubing only in areas where temperatures will remain above freezing.

Tools required

- Standard screwdriver
- 7/16 in. and ½ in. open-end wrenches or two adjustable wrenches
- ¼ in. nut driver
- ¼ in. drill bit
- Hand drill or electric drill properly grounded

NOTE: Your ice maker dealer has a kit available with a ¼ in. (6.35 mm) saddle-type shutoff valve, a union, and copper tubing. Before purchasing, make sure a saddle-type valve complies with your local plumbing codes. Do not use a piercing-type or 3/16 in. (4.76 mm) saddle valve which reduces water flow and clogs more easily.

Connecting the water line

1. Turn off main water supply. Turn on nearest faucet long enough to clear line of water.
2. Find a ½ in. (12.70 mm) to 1¼ in. (3.18 cm) vertical cold water pipe near the ice maker.

NOTE: Horizontal pipe will work, but the following procedure must be followed: Drill on the top side of the pipe, not the bottom. This will help keep water away from the drill. This also keeps normal sediment from collecting in the valve.

3. Using a grounded drill, drill a ¼ in. (6.35 mm) hole in the cold water pipe you have selected.
4. Fasten shutoff valve to cold water pipe with pipe clamp. Be sure outlet end is solidly in the ¼ in. (6.35 mm) drilled hole in the water pipe and that washer is under the pipe clamp. Tighten the pipe clamp screws carefully and evenly so washer makes a watertight seal. Do not overtighten the pipe clamp or you may crush cold water pipe if it is soft copper tubing. Do not use a piercing-type or ¾ in. (4.76 mm) saddle-type valve which reduces water flow and clogs more easily.
5. Now you are ready to connect the copper tubing. Use ¼ in. (6.35 mm) OD soft copper tubing for the cold water supply.
 - Measure from the connection at the front of the ice maker to the cold water pipe. Add 3 ft (91.4 cm) to ensure that you have the proper length. This is the length of ¼ in. (6.35 mm) OD soft copper tubing you need for the job. Be sure both ends of the copper tubing are cut square.
 - Slip compression sleeve and compression nut on copper tubing as shown. Insert end of tubing into outlet end squarely as far as it will go. Screw compression nut onto outlet end with adjustable wrench. Do not overtighten.

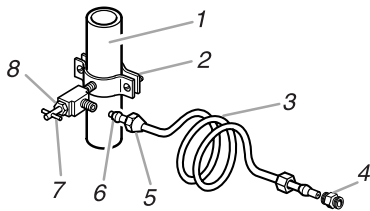

- | | |
|-------------------------|-----------------------|
| 1. Cold Water Pipe | 5. Compression Nut |
| 2. Pipe Clamp | 6. Compression Sleeve |
| 3. Copper Tubing | 7. Shutoff Valve |
| 4. Coupling (purchased) | 8. Packing Nut |

6. Place the free end of the tubing into a container or sink, and turn on main water supply and flush out tubing until water is clear. Turn off shutoff valve on the water pipe.

NOTE: Always drain the water line before making the final connection to the inlet of the water valve to prevent possible water valve malfunction.

7. Bend the copper tubing to meet the water line inlet which is located on the back of the ice maker cabinet as shown.

REAR VIEW

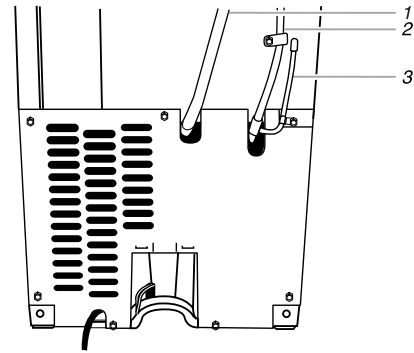

1. Drain Hose (Drain Pump models only)
2. Vent Hose (Drain Pump models only)
3. Water Supply Line

8. Thread the nut onto the coupling on the end of the copper tubing. Tighten the nut by hand. Then tighten it with a wrench two more turns. Do not overtighten.

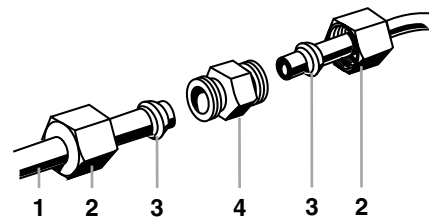

1. Line to ice maker
2. Nut (purchased)
3. Ferrule (purchased)
4. Coupling (purchased)

9. Remove the two screws in the lower access panel and the two screws in the base grille area of the front panel support. Pull forward to remove the lower access panel.

NOTE: To prevent rattling, be sure the copper tubing does not touch the cabinet's side wall or other parts inside the cabinet.

FRONT VIEW

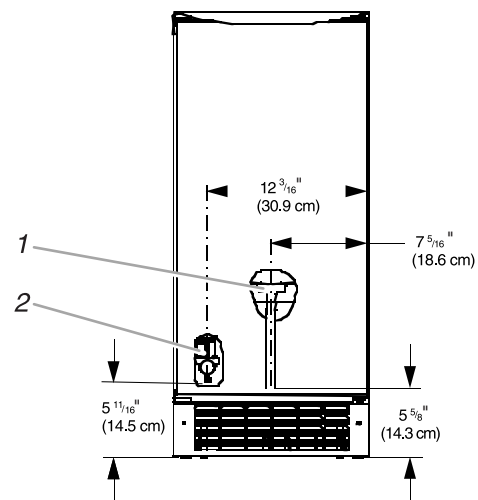

1. Water Pan Drain
2. Water Valve

10. Turn shutoff valve ON.
11. Check for leaks. Tighten any connections (including connections at the valve) or nuts that leak.
12. Replace the lower access panel and screws.

Connecting the drain

Gravity drain system

Connect the ice maker drain to your drain in accordance with all state and local codes and ordinances. If the ice maker is provided with a gravity drain system, follow these guidelines when installing drain lines. This will prevent water from flowing back into the ice maker storage bin and potentially flowing onto the floor causing water damage.

- Drain lines must have a minimum of $\frac{5}{8}$ in. (15.88 mm) inside diameter.
- Drain lines must have a 1 in. drop per 48 in. (2.54 cm drop per 122 cm) of run or $\frac{1}{4}$ in. drop per 12 in. (6.35 mm per 30.48 cm) and must not have low points where water can settle.
- The floor drains must be large enough to accommodate drainage from all drains.
- The ideal installation has a standpipe with a $1\frac{1}{2}$ in. (3.81 cm) to 2 in. (5.08 cm) PVC drain reducer installed directly below the outlet of the drain tube as shown. You must maintain a 1 in. (2.54 cm) air gap between the drain pump hose and the standpipe.
- It may be desirable to insulate the drain line thoroughly up to the drain inlet.

After ensuring that the drain system is adequate, follow these steps to properly place the ice maker:

1. Plug in ice maker or reconnect power.
2. Recheck the ice maker to be sure that it is level. See the "Leveling" section.
3. Push the ice maker into position so that the ice maker drain tube is positioned over the PVC drain reducer.

SIDE VIEW

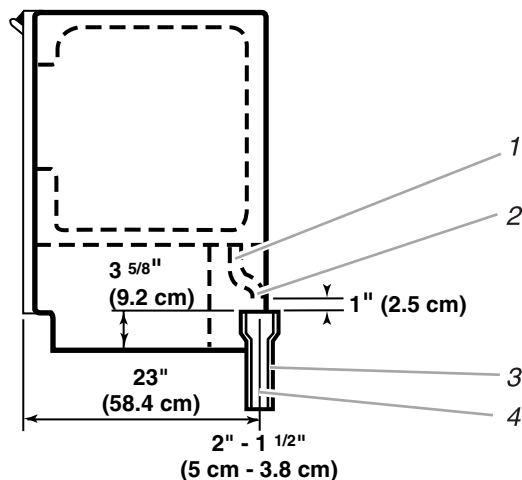

1. Drain Hose
2. 1 in. (2.54 cm) Air Gap
3. PVC Drain Reducer
4. Center of drain should be 23 in. (58.4 cm) from front of door (with or without the $\frac{1}{4}$ in. (1.91 cm) panel on the door).

4. If it is required by your local sanitation code, seal the cabinet to the floor with an approved caulking compound after all water and electrical connections have been made.

Drain pump system (on some models)

Connect the drain pump hose (provided with the product) to your drain in accordance with all state and local codes and ordinances.

NOTE: If the drain hose becomes twisted and water cannot drain, your ice maker will not work.

Reversing the Door Swing

TOOLS NEEDED: $\frac{5}{16}$ in. wrench, $\frac{1}{4}$ in. wrench, flat putty knife, Phillips screwdriver

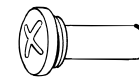

Hinge Pin

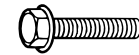

$\frac{5}{16}$ -inch Hex Head Hinge Screw



Handle Screw

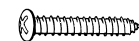

Endcap Screw

To remove door from hinges:

⚠ WARNING



Electrical Shock Hazard

Disconnect power before servicing.
Replace all parts and panels before operating.
Failure to do so can result in death or electrical shock.

1. Unplug ice maker or disconnect power.
2. Remove the handle screws and handle (on some models). Keep the parts together and set them aside.
3. Remove the two hex head screws from the upper access panel. Lift up on the bottom of the access panel to release it from the front of the ice maker. Do not disconnect the wires.

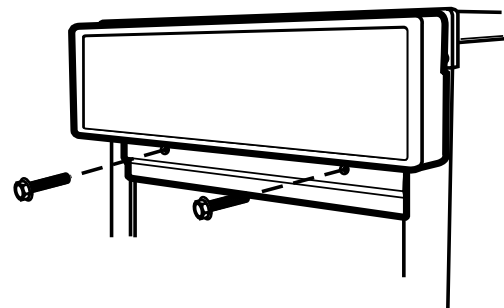

4. With the upper access panel raised, remove the hinge pin from the top hinge.
5. Remove the door from the hinges and screw the top hinge pin back into the top hinge.
6. Replace the upper access panel loosely on the ice maker.
7. Reverse the door endcaps as follows:
 - Remove both the screws and endcaps (top and bottom).
 - Place the top endcap on the bottom of the opposite side of the door with the long flat side facing the door front.
 - Place the bottom endcap on the top of the opposite side of the door with the long flat side facing the door front.
8. Set the door aside.

To reverse the hinges:

1. Unscrew and remove the top hinge. Replace the screws in the empty hinge holes.
2. Remove the screws from the bottom of the opposite side of the ice maker cabinet. Turn the top hinge upside down so that the hinge pin points up. Place the hinge on the bottom opposite side of the ice maker and tighten screws.
3. Remove the plastic hinge pin sleeve from the “old” bottom hinge and replace it on the new bottom hinge pin.
4. Remove the “old” bottom hinge screws and hinge. Replace the screws in the empty hinge holes.
5. Remove the screws from the top of the opposite side of the ice maker cabinet. Turn the hinge upside down so that the hinge pin points down.
6. Raise the upper access panel and place the hinge on the top opposite side of the ice maker. Tighten the hinge screws.
7. Remove the top hinge pin.

To replace door on hinges:

1. Place plastic hinge pin sleeve in the top hinge hole on the door. Align the door with the top hinge hole and replace the top hinge pin.
2. Replace the upper access panel and secure it with the hex head screws.
3. Replace the handle and handle screws.

Top Hinge

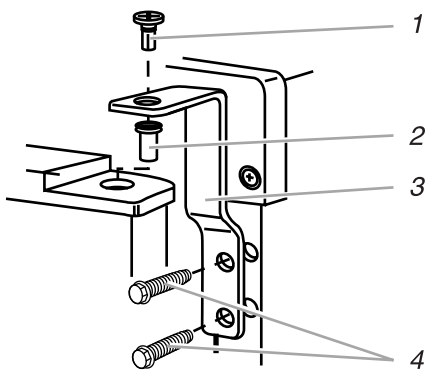

1. Hinge Pin
2. Hinge Pin Sleeve
3. Hinge
4. Hex Head Hinge Screw

Bottom Hinge

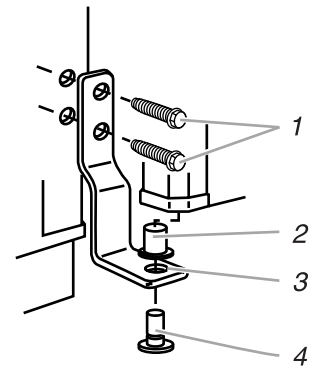

1. Hex Head Hinge Screw
2. Hinge Pin Sleeve
3. Hinge
4. Hinge Pin

To reverse the door catch:

1. Remove the hole plugs from the opposite side of the door and set aside.
2. Remove the screws from the magnetic door catch and replace it on the opposite side of the door.
3. Push the hole plugs into place on the opposite side of the door.
4. Plug in ice maker or reconnect power.

Normal Sounds

Your new ice maker may make sounds that are not familiar to you. Because the sounds are new to you, you might be concerned about them. Most of the new sounds are normal. Hard surfaces such as the floor, walls and cabinets can make the sounds seem louder than they actually are. The following describes the kinds of sounds that might be new to you and what may be making them.

- You will hear a buzzing sound when the water valve opens to fill the water reservoir for each cycle.
- Rattling noises may come from the flow of the refrigerant or the water line. Items stored on top of the ice maker can also make noises.
- The high efficiency compressor may make a pulsating or high pitched sound.
- Water running over the evaporator plate may make a splashing sound.
- Water running from the evaporator plate to the water reservoir may make a splashing sound.
- As each cycle ends, you may hear a gurgling sound due to the refrigerant flowing in your ice maker.
- You may hear air being forced over the condenser by the condenser fan.
- During the harvest cycle, you may hear a “thud” when the ice sheet slides from the evaporator onto the cutter grid.
- When you first start the ice maker, you may hear water running continuously. The ice maker is programmed to run a rinse cycle before it begins to make ice.

ICE MAKER USE

How Your Ice Maker Works

When you first start your ice maker, the water pan will fill and the system will rinse itself before starting to make ice. The rinsing process takes about five minutes.

Under normal operating conditions, the ice maker will cycle at preset temperatures. The ice level sensor located in the ice storage bin will monitor the ice levels.

IMPORTANT:

- If the water supply to the ice maker is turned off, be sure to set the ice maker control to OFF.
- The ice maker is designed to make clear ice from the majority of water sources on a daily basis. If your results are unsatisfactory, your water may need to be filtered or treated.

The Ice Making Process

1. Water is constantly circulated over a freezing plate. As the water freezes into ice, the minerals in the water are rejected. This produces a clear sheet of ice with a low mineral content.

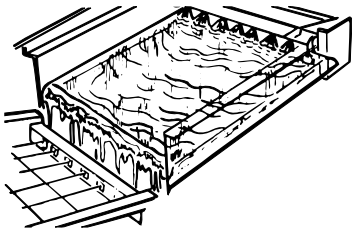

2. When the desired thickness is reached, the ice sheet is released and slides onto a cutter grid. The grid divides the sheet into individual cubes.

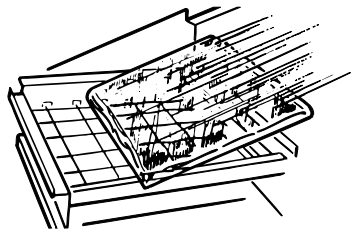

3. The water containing the rejected minerals is drained after each freezing cycle.
4. Fresh water enters the machine for the next ice making cycle.

5. Cubes fall into the storage bin. When the bin is full, the ice maker shuts off automatically and restarts when more ice is needed. The ice bin is not refrigerated, and some melting will occur. The amount of melting varies with room temperature.

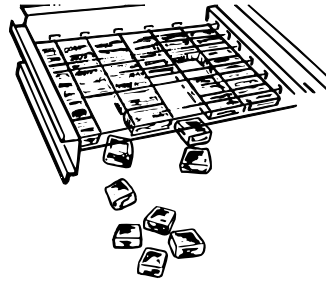

NOTE: As the room and water temperatures vary, so will the amount of ice produced and stored. This means that higher operating temperatures result in reduced ice production.

Using the Controls

1. To start the normal ice making cycle, select ON.
2. To stop ice maker operation, select OFF.

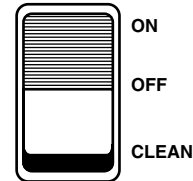

NOTE: The CLEAN setting is used whenever solutions are circulated through the ice maker for cleaning. Only the water pump and compressor operate at this setting. See the "Cleaning" section.

ICE MAKER CARE

Cleaning Exterior Surfaces

Wash the exterior enamel surfaces and gaskets with warm water and mild soap or detergent. Wipe and dry. Regular use of a good household appliance cleaner and wax will help protect the finish. Do not use abrasive cleaners on enamel surfaces as they may scratch the finish.

For products with a stainless steel exterior, use a clean sponge or soft cloth and a mild detergent in warm water. Do not use abrasive or harsh cleaners.

Cleaning the Ice Maker System

Minerals that are removed from water during the freezing cycle will eventually form a hard scaly deposit in the water system. Cleaning the system regularly helps remove the mineral scale buildup. How often you need to clean the system depends upon how hard your water is. With hard water of 15 to 20 grains/gal. (4 to 5 grains/liter), you may need to clean the system as often as every 6 months.

NOTE: Use one 16 oz (473 mL) bottle of NU-CALGON* Nickel Safe Ice Machine Cleaner. To order, call **1-800-442-9991** and ask for Part Number 8171307. In Canada, call **1-800-807-6777**.

1. Push the selector switch to OFF.
2. Wait 5 to 10 minutes for the ice to fall into the storage bin. Remove all ice from the storage bin.
3. Unscrew the drain cap from the bottom of the water pan located inside the storage bin as shown. Allow the water to drain completely.
4. Replace the drain cap securely on the water pan. If the drain cap is loose, water will empty from the water pan and you will have either thin ice or no ice.
5. Read and follow all handling information on the cleaner bottle before completing the steps below. Use one 16 oz (473 mL) bottle of NU-CALGON* Nickel Safe Ice Machine Cleaner.
6. Pour one bottle of solution into the water pan. Fill the bottle twice with tap water and pour it into the water pan.

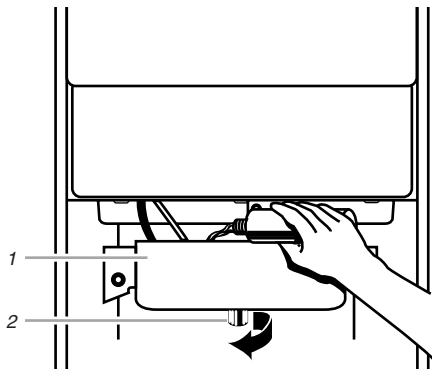

1. Water Pan
2. Drain Cap

7. Push the selector switch to CLEAN. (See the “Using the Controls” section.) The light will turn on, indicating that the cleaning cycle is in process. When the indicator light turns off (approximately 45 minutes), the cleaning cycle is complete. During the cleaning cycle, the system will both clean and rinse itself.
8. After the cleaning cycle is complete, remove the drain cap from the water pan to see if any cleaning solution is left in the water pan. If cleaning solution drains from the water pan, you should run the clean cycle again. Be sure to replace the drain cap securely on the water pan. If the drain cap is loose, water will empty from the water pan and you will have either thin ice or no ice.

NOTE: Severe scale buildup may require repeated cleaning with a fresh quantity of cleaning solution.

9. Push the selector switch to ON to resume ice production.

Cleaning the Condenser

A dirty or clogged condenser:

- Prevents proper airflow.
- Reduces ice making capacity.
- Causes higher than recommended operating temperatures which may lead to component failure.

! WARNING



Electrical Shock Hazard

Disconnect power before cleaning.

Replace all panels before operating.

Failure to do so can result in death or electrical shock.

1. Unplug ice maker or disconnect power.
2. Remove the two screws in the lower access panel and the two screws from the base grille area of the front panel support. Pull forward to remove the lower access panel.
3. Pull the bottom forward and then pull down to remove the lower access panel.

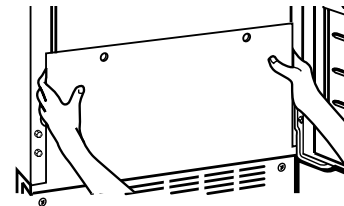

4. Remove dirt and lint from the condenser fins and the unit compartment with a brush attachment on a vacuum cleaner.

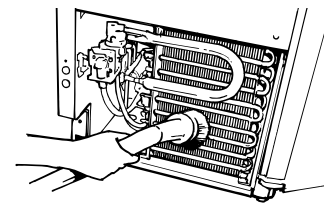

5. Replace the lower access panel using the four screws.
6. Plug in ice maker or reconnect power.

*NU-CALGON is a trademark of Calgon Corporation.

Cleaning the Interior Components

1. Unplug ice maker or disconnect power.
2. Open the storage bin door and remove any ice that is in the bin.
3. Remove the drain cap from the water pan and drain thoroughly. Replace the drain cap securely on the water pan. If the drain cap is loose, water will empty from the water pan, and you will have either thin ice or no ice.
4. Remove the three screws that hold the cutter grid cover in place.
5. Unplug the wiring harness from the left side of the cutter grid.

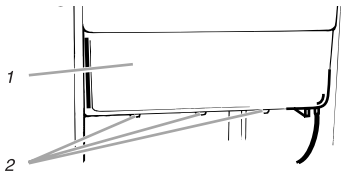

1. Cutter Grid Cover
2. Screws

6. Unplug the ice level sensor from the right side of the cutter grid. Pull the ice level sensor down and forward away from the cutter grid.
7. Remove the right-hand screw and loosen the left-hand screw. Lift the cutter grid up and out and over the left-hand screw.

NOTE: Make sure the plastic spacer from the right-hand side of the cutter grid bracket stays with the cutter grid.

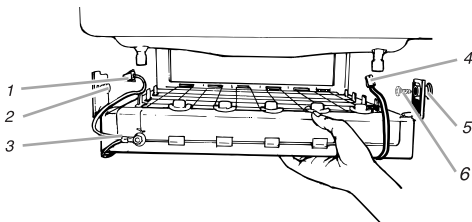

1. Cutter Grid Harness 4. Ice Level Sensor Harness
2. Screw 5. Plastic Spacer
3. Cutter Grid 6. Screw

8. Remove the two screws that hold the water pan in place. Push down with one hand on the front of the pan while pulling forward on the bottom back side.

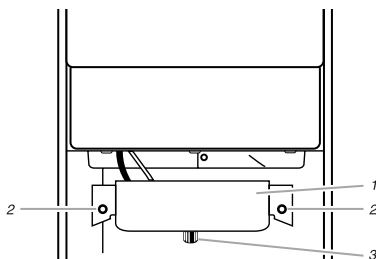

1. Water Pan
2. Water Pan Screws
3. Drain Cap

9. Wash the interior components (cutter grid, exterior of hoses, and water pan) and the storage bin, door gasket, and ice scoop with mild soap or detergent and warm water. Rinse in clean water. Then clean the same parts with a solution of 1 tablespoon (15 mL) of household bleach in 1 gal. (3.8 L) warm water. Rinse again thoroughly in clean water.

NOTE: Do not remove hoses. Do not wash plastic parts in dishwasher. They cannot withstand temperatures above 145°F (63°C).

10. Replace water pan by pushing back on the bottom with one hand while pushing up and back on the top. Secure the water pan by replacing both screws.
11. Check the following:
 - Drain cap from the water pan is securely in place. If the drain cap is loose, water will empty from the water pan, and you will have either thin ice or no ice.
 - Hose from water pan is inserted into storage bin drain opening.
12. Slide the cutter grid back into place and secure it by replacing the right-hand screw and plastic spacer. Then tighten the left-hand screw. Reconnect the cutter grid harness and the ice level sensor harness.
13. Plug in ice maker or reconnect power.

Vacation and Moving Care

⚠ WARNING



Electrical Shock Hazard

Disconnect power before servicing.

Replace all parts and panels before operating.

Failure to do so can result in death or electrical shock.

To shut down the ice maker:

1. Unplug ice maker or disconnect power.
2. Remove all ice from storage bin.
3. Shut off the water supply.

- Remove the two screws in the lower access panel and the two screws from the base grille area of the front panel support. Pull forward to remove the lower access panel.

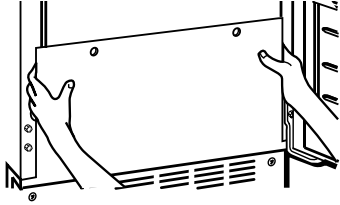

- Disconnect the inlet and outlet lines to water valve. Allow these lines to drain and then reconnect to the valve.
- Replace lower access panel and screws.
- Drain water from water pan by removing the drain cap.
- If the room temperature will drop below 32°F (0°C), remove water from the drain line.
For ice makers with a drain pump installed:
 - Plug in ice maker or reconnect power.
 - Turn ice maker off and remove all remaining ice from ice bin.
 - Pour 1 quart (0.95 L) of water into the ice bin near the drain and let the unit stand for approximately five minutes. This will allow the water in the bin to drain into the drain pump so that the pump will remove the remaining water from the ice bin and the drain pump.
 - Unplug ice maker or disconnect power.
- Before using again, clean the ice maker and storage bin.
- Plug into a grounded 3 prong outlet.

NOTE: All components of the ice maker are permanently lubricated at the factory. They should not require any additional oiling throughout the normal life of the machine.

TROUBLESHOOTING

Try the solutions suggested here first in order to avoid the cost of an unnecessary service call.

Unit does not run

- Is the control set to ON?** Be sure that the control is set to ON.
- Is the power cord plugged in?** Plug into a grounded 3 prong outlet.
- Has a household fuse or circuit breaker tripped?** Replace the fuse or reset the circuit.
- Is the room temperature cooler than normal?** Room temperature must be above 55°F (13°C). Otherwise, bin thermostat may sense cold room temperature and shut off even though bin is not full of ice. Also, unit may not restart once it does shut off.

Unit runs but produces no ice

- Is the control set to ON?** Be sure that the control is set to ON.
- Is the water supply connected?** Make sure the water supply is properly connected and turned on.

Unit runs but produces very little ice

- Is the room temperature hotter than normal?** Room temperatures of more than 90°F (32°C) will normally reduce ice production.
- Is the condenser dirty?** Dirt or lint may be blocking the airflow through the condenser. See the “Condenser” section.
- Is there scale buildup in the ice maker?** If there is white scale buildup in the ice maker’s water or freezing system, you should clean the ice maker. See the “Ice Maker System” and the “Interior Components” sections.
- Is the drain cap securely in place?** Tighten the drain cap if it is loose. If the drain cap is loose, water will empty from the water pan, and you will have either thin ice or no ice.

Grid is not cutting ice sheets

- Is the cutter grid securely in place?** Unplug the ice maker or disconnect power. Remove the cutter grid cover and check the cutter grid harness plug to make sure the connection is secure.

Taste in ice cubes

- Is there unusually high mineral content in the water supply?** The water may need to be filtered or treated.
- Are there food items stored in the ice bin?** Do not store any foods in the ice bin.
- Were all the packaging materials removed?** Make sure that all packaging materials were removed at the time of installation.

CORNELIUS LIMITED WARRANTY PLAN

TO THE ORIGINAL OWNER OF A CORNELIUS MODEL ACS50SL CUBE ICE MAKER

Limited to equipment located in the fifty United States and the Canadian Provinces.

PARTS WARRANTY PERIOD

IMI CORNELIUS INC., hereinafter referred to as CORNELIUS, warrants to the original owner of a new CORNELIUS Model ACS50SL cube ice machine ("Machine"), that the Machine shall be free from defects in material and/or factory workmanship if properly installed, operated, and maintained, under normal and proper use and service conditions with competent supervision. The parts warranty period is one year (12 months) from the date of installation or 15 months from the date of shipment by CORNELIUS whichever time period elapses first. In addition, the motor compressor will be warranted for 1 (one) year (12 months) from date of installation or 15 months from date of shipment by CORNELIUS. The obligation of CORNELIUS under this warranty is limited to repair or replacement (at the option of CORNELIUS) FOB factory in Mason City, Iowa, of the part (or parts) of any Machine that is proven defective.

LIMITED LABOR WARRANTY PERIOD

In addition to the parts warranty, CORNELIUS will pay scheduled straight time labor to repair or replace a defective component when failure occurs within 1 years (12 months) from the date of installation, or 15 months from date of shipment by CORNELIUS whichever comes first. Such service is to be performed by a service agency authorized by CORNELIUS. Time and rate schedules for labor compensation will be published periodically by CORNELIUS. Additional expenses including but not limited to travel time, truck charges, overtime charges, material costs, accessing of removal of the ice machine, normal prescribed maintenance cleaning, adjustments, and ice purchases are the responsibility of the original owner.

No parts warranty on the motor compressor assembly will apply when the ice machine's refrigeration system is modified with a condenser heat reclaim device, or parts and assemblies not provided by CORNELIUS, unless CORNELIUS provides approval in writing, for these modifications for specific locations.

The parts warranty shall not apply when destruction or damage is caused by alterations, unauthorized service, using other than factory authorized replacement parts, risks of transportation, accidents, misuse, damage by fire, flood, or acts of God. No components or assembly from which the serial number of identification number has been altered or removed will be covered. Any defective parts to be repaired or replaced must be returned to us through a CORNELIUS distributor/dealer, transportation charges prepaid and they must be properly sealed and tagged. The serial and model number of the Machine and the date of original installation of such Machine must be given. The warranty of repaired or replaced parts will not extend beyond the period of the original warranty. The decision of the CORNELIUS Service Department regarding the warrantability of parts and eligibility for the labor allowance will be final.

No representative, distributor/dealer or any other person is authorized or permitted to make any other warranty or obligate CORNELIUS to any liability not strictly in accordance with this policy. This warranty is in lieu of all other warranties expressed or implied and of all other obligations or of liabilities on our parts.

OUR LIABILITIES ARE LIMITED SOLELY AND EXCLUSIVELY TO REPAIR OR REPLACEMENT OF THE DEFECTIVE PRODUCT. WE ARE NOT LIABLE FOR ANY SPECIAL INCIDENTAL OR CONSEQUENTIAL DAMAGES OF ANY KIND WHATSOEVER. In those jurisdictions where liability for damages cannot be disclaimed, original purchaser's recovery shall not exceed the cost of the warranted product.

Except for descriptions of size, quantity, and type, which may appear on CORNELIUS products with specifications of certain industry, government, or professional organization's standards which may appear as product information disclosures in CORNELIUS literature and other documents from time to time, THIS WARRANTY IS IN LIEU OF AND EXCLUDES ALL OTHER WARRANTIES, EXPRESSED OR IMPLIED, INCLUDING WARRANTIES OR MERCHANTABILITY AND FITNESS FOR A PARTICULAR PURPOSE.

Effective March 1, 1994

IMPORTANT

Be sure to return your warranty registration card to CORNELIUS immediately upon installation of your ice maker. Failure to do so may void this warranty.

Keep this book and your sales slip together for future reference. You must provide proof of purchase or installation date for in-warranty service.

Write down the following information about your ice maker to better help you obtain assistance or service if you ever need it. You will need to know your complete model number and serial number. You can find this information on the model and serial number label, located on your appliance as shown in the "Parts and Features" section of this book.

**IMI CORNELIUS INC
ONE CORNELIUS PLACE
ANOKA, MINNESOTA 55303-6234
612-421-6120**

Dealer name _____

Address _____

Phone number _____

Model number _____

Serial number _____

Purchase date _____

NOTICE

YOU MUST REGISTER YOUR WARRANTY REGISTRATION CARD

Please fill out this Warranty Registration Card when your Ice Maker is installed.

ORIGINAL OWNER

Model No. _____ Serial No. _____
Gear Motor _____ Condensing Unit _____
Serial No. _____ Serial No. _____

WARRANTY REGISTRATION CARD TO BE MAILED AT TIME OF INSTALLATION

Installation Date _____

Owner's Name _____ Type of Business _____

Address _____

City _____ State _____

Unit Installed Under Bar () In Kitchen () In Basement ()

Other () Explain _____

Upon receipt of this card, your Ice Maker will be registered to contain the protection of the warranty of defective workmanship and/or material. This warranty is effective from the date of original installation by the dealer and is not transferable.

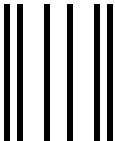

NO POSTAGE
NECESSARY
IF MAILED
IN THE
UNITED STATES

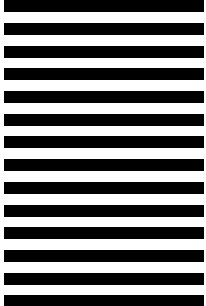

BUSINESS REPLY MAIL
FIRST CLASS MAIL PERMIT NO. 82 MASON CITY, IA

POSTAGE WILL BE PAID BY ADDRESSEE

IMI CORNELIUS INC.
2421 15th Street S.W.
P.O.Box 1527
Mason City, Iowa 50401-9952